

Applications: snap-on metal fasteners for panelling and cladding by press-fitting, panel removal by pulling

Mounting: on structure by screwing, gluing, riveting

Female

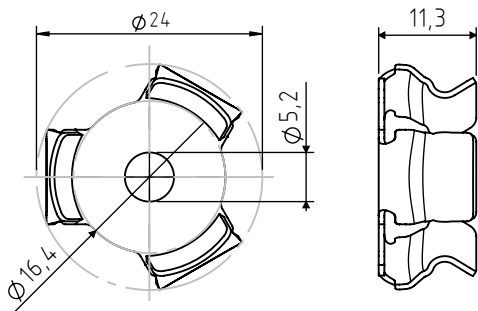

Male

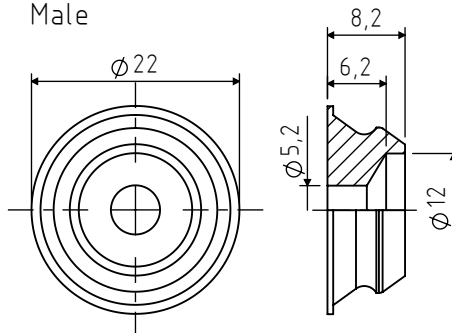

code	material	extraction load
FC-01-FE.51	inox 316	min 7kg
FC-01-FE.53	inox 301	min 10kg

code	material
FC-02-MA.51	inox 316
FC-02-MA.50	inox 303

Values and dimensions are indicative, not binding - dimensions expressed in mm.

 Standard

 On demand

Accessories:
FC-01-CE.50 centering device



FC-00-LE.12 release lever



Application example:
FAST-CON® built-in

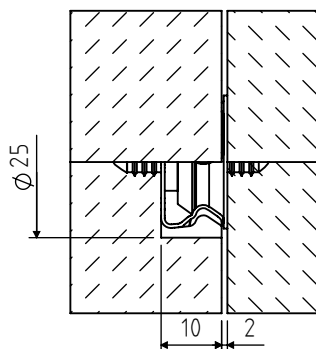

FAST-CON® flush-mounted

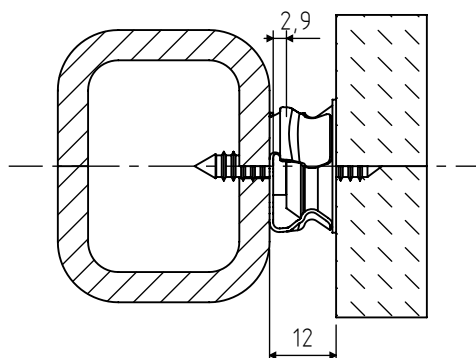

PLEASE NOTE: For the installation guide, please contact the Specialinsert® technical/commercial department or consult the catalogue downloadable from our website www.specialinsert.it